

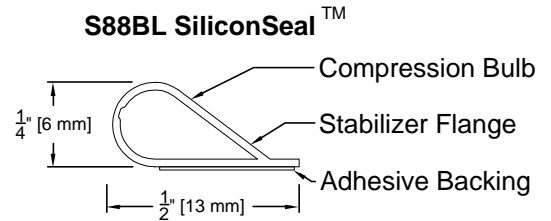

ACOUSTICAL DOOR (STC)

U.S.A. : 1.800.363.2248
 Can. : 1.800.463.3124

REQUIRED HARDWARE

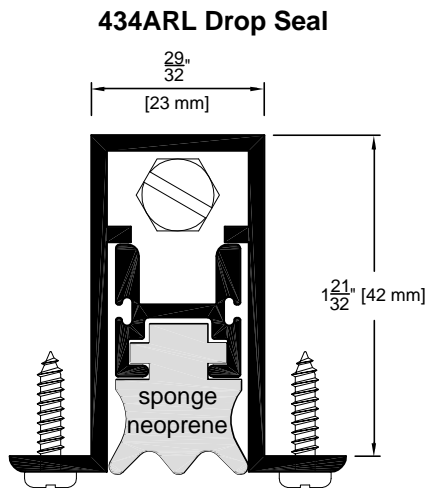

AVAILABLE IN BLACK ONLY

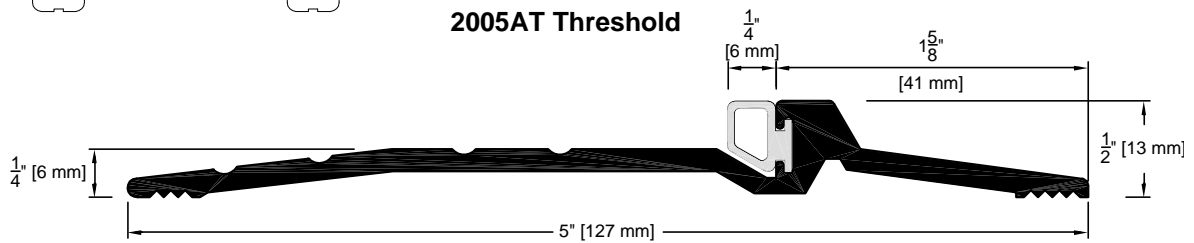

Lambton Doors cannot be responsible for field measurements. All STC doors must be undersized $\frac{1}{2}$ " (13 mm) in total from frame height after finished floor (AFF).

Eg. frame 7'0" (2134 mm).

Top of door to frame less $\frac{1}{8}$ " (3 mm).

Bottom of door to threshold less $\frac{3}{8}$ " (10 mm).

Total door to frame difference after finished floor less $\frac{1}{2}$ " (13 mm).

REQUIRED FRAME AND ASTRAGAL

Frame : Any standard 16 ga. hollow metal frame

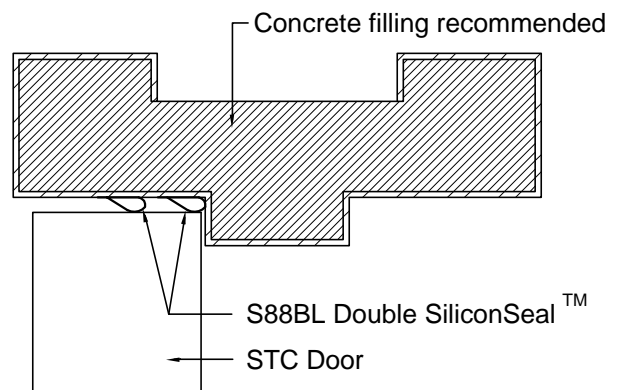
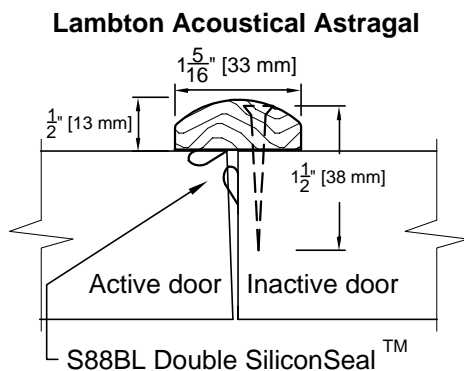

Note : Gaskets are shown in full size (non-compressed).

Lambton Doors recommends the use of $1\frac{1}{2}$ " [38 mm] brass screws for installation.

• Standard metal frame supplied by others.