

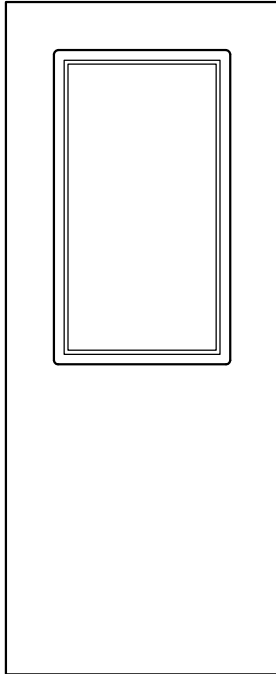

U.S.A. : 1.800.363.2248  
 Can. : 1.800.463.3124

## SLIMLINE MODEL by AIR LOUVERS Inc.



Low Profile Beveled VISION LITE with continuous glass retainer.  
 Recommended for applications where low profile, total visibility and light transmissions are required.

### Specifications

#### Standard Features :

**Material :** 20 gauge CRS frame.

**Construction :** Radius Corners, mitered and welded. Continuous glass retainer, countersunk mounting holes in bevel return. Screws fasten from room side into prepunched internal mounting holes. This mounting method leaves corridor side of frame free of fasteners for aesthetic and security purposes.

**Finish :** Mineral bronze baked on power coat.

**Door :** For 1-3/4" [44 mm] door.

**Fasteners :** #8 x 7/8" [22 mm] flathead philips head SMS.

**Glass :** Use 3/16" [5 mm], 1/4" [6 mm], 5/16" [8 mm] fire rated glazing with Warnock Hersey(ITS) or U.L. classification markings for fire rated applications.

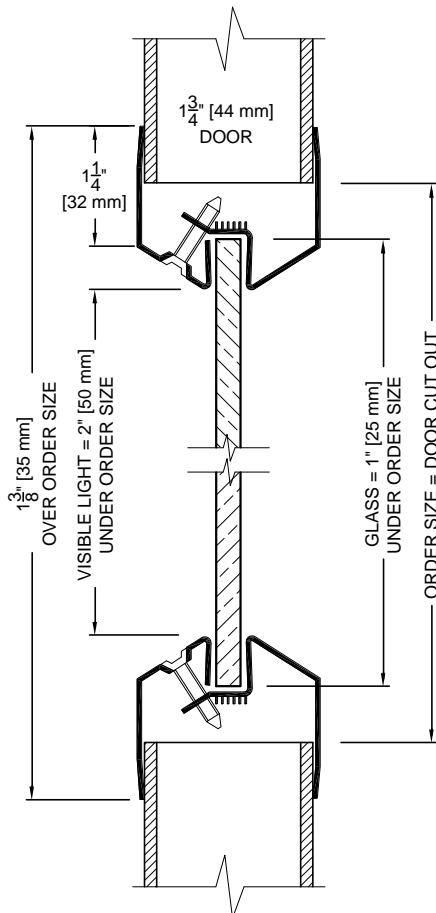

#### Fire Ratings with Warnock Hersey (ITS) or U.L. Classification Markings :

##### Using 1/4" [6 mm] thick listed wire glass

- 20, 45, 60, 90 Minute.

##### Using 3/16" [5 mm] thick PYROSWISS EXTRA

- 20 Minutes without hose stream test.

##### Using 5/16" [8 mm] thick KERALITE-FRL

- 20 Minutes to 3 hours.

##### Using 3/16 [5 mm] KERALITE-FRF

- 20 Minutes to 3 hours.

This Product is Listed by  
 UNDERWRITERS LABORATORIES INC.  
 and Bears the Mark :



Warnock Hersey



TESTED AND LISTED FOR U.L. 10C AND  
 CRITERIA OF UBC 7-2 POSITIVE PRESSURE