

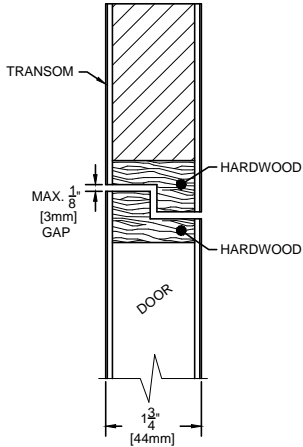

COMMERCIAL AND ARCHITECTURAL
DOOR MANUFACTURER

U.S.A. : 1 800 363.2248
Can. : 1 800 463.3124
info@lambtondoors.com
www.lambtondoors.com

NON-RATED DOOR WITH TRANSOM



- Door construction according to series except for meeting transom rails.
- The maximum single opening size is 4'-0" x 10'-0" [1219 mm x 3048 mm].
- The maximum pair opening size is 8'-0" x 10'-0" [2438 mm x 3048 mm].
- The panel shall be machined for spring bolts.

APPROVED STEEL SPRING BOLTS : "STANLEY #1697"

Panel up to 18" [457 mm] in height= 2 spring bolts per side
Panel up to 36" [914 mm] in height= 3 spring bolts per side
Panel up to 40" [1016 mm] in height= 4 spring bolts per side

SIDE VIEW DETAILS RABBETTED MEETING RAILS

