

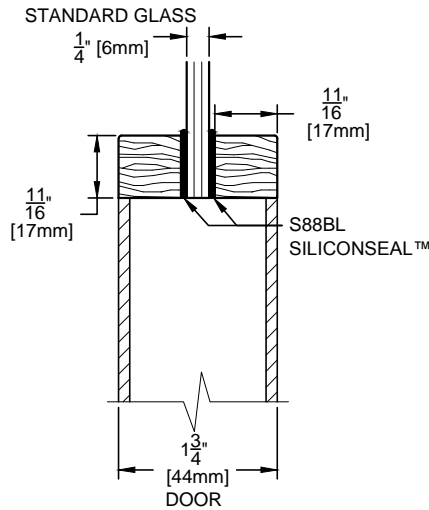

COMMERCIAL AND ARCHITECTURAL
DOOR MANUFACTURER

U.S.A. : 1 800 363.2248
Can. : 1 800 463.3124
info@lambtondoors.com
www.lambtondoors.com

LITE BEADS ACOUSTICAL DOOR STC 27, 31 & 35 NON FIRE-RATED



LB7-STC- $\frac{1}{4}$ "

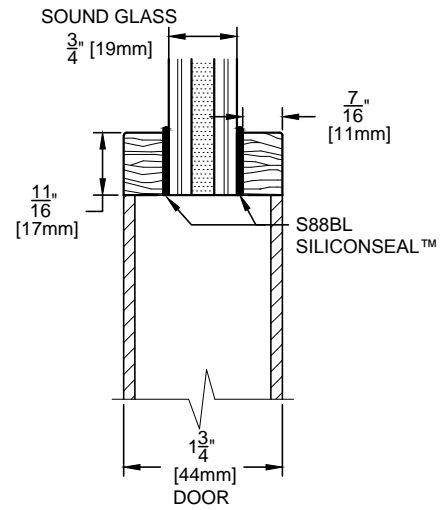

LB7-STC- $\frac{3}{4}$ "

MAXIMUM SIZE 1296 sq. in. (0.836 sq. m.)
STC RATING WILL BE AFFECTED

INSTALLATION INSTRUCTIONS FOR FIELD GLAZING ACOUSTICAL DOOR STC 27 , 31 & 35 NON FIRE-RATED

Lite beads that are firmly pre-installed in the factory, on one side of the door, are not to be removed. You must remove the lite beads on the other side of the door. Although they are also pre-installed in the factory you will notice that they can be easily removed.

1. Apply the self-adhesive S88BL SiliconSeal™ directly on the mouldings that are firmly pre-installed in the factory.
2. Apply 1/8" (3 mm) bead of silicon caulk on the joint of the self-adhesive S88BL SiliconSeal™ and the door core.
3. Install the glass and press firmly against the silicon caulk.
4. Apply the self-adhesive S88BL SiliconSeal™ to the perimeter of the glass.
5. Apply 1/8" (3 mm) bead of silicon caulk on the joint of the self-adhesive S88BL SiliconSeal™ and the door core.
6. Re-install firmly against the silicone caulk the second lite beads using the pre-machined holes.
7. Install lite beads using casing nails of gage 23 x 1-1/4" (32 mm). A minimum of 2 nails are required per bead. Position the first nails no closer than 2" (51 mm) from corners. Maximum spacing between all nails is 12" (305 mm).