

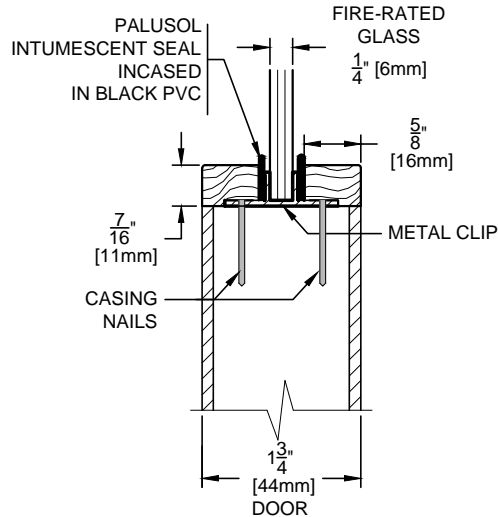

COMMERCIAL AND ARCHITECTURAL
DOOR MANUFACTURER

U.S.A. : 1 800 363.2248
Can. : 1 800 463.3124
info@lambtondoors.com
www.lambtondoors.com

LITE BEADS ACOUSTICAL DOOR STC 27 & 31 20 MINUTE FIRE-RATED



LB7-20

(NEUTRAL OR POSITIVE PRESSURE)

MAXIMUM SIZE 1296 sq. in. (0.836 sq. m.)
STC RATING WILL BE AFFECTED

INSTALLATION INSTRUCTIONS FOR FIELD GLAZING ACOUSTICAL DOOR STC 27 & 31 20 MINUTE FIRE-RATED

1. METAL CLIPS. Insert the metal clips on the 4 sides of the fire-rated glass. 2 clips minimum are required per side. Position the first clips at 9" (229 mm) maximum from each glass corners. Maximum spacing between all clips is 18" (457 mm).
2. GLASS. Install the glass, with its metal clips, into the door opening. Fix the glass to the opening using casing nails of gage 23 x 1-1/4" (32 mm) directly in the metal clips.
3. SILICON CAULK. Apply 1/8" (3 mm) of silicon caulk on the joint of the glass perimeter with the door core.
4. INTUMESCENT SEAL. Apply Palusol auto-adhesive intumescent seal (incased in black PVC) on one of the 4 glass side. Be sure the seal is PERFECTLY ALIGNED with the glass edge meaning that no glass is uncovered along the edge. Apply a second seal perpendicular to the first one and be sure that both adjoining extremities, 90 degrees cutted, fit perfectly together with no glass uncovered. Do the same with the two other sides of the glass.
5. WOOD BEADS. Install wood beads using casing nails of gage 23 x 1-1/4" (32 mm). A minimum of 2 nails are required per bead. Firmly tighten the bead against the intumescent seal before nailing. Maximum spacing between each nails is 12" (305 mm).
6. Repeat steps 2 (casing nails), 3, 4 and 5 on the other side of the door.